

M-16i

Basic Description

The FANUC M-16i and long-arm M-16iL robots are engineered for precision, high-speed operation, user-friendly setup and maximum reliability, supported by our extensive service and parts network. The M-16i is a six-axis, modular construction, electric servo-driven robot designed for a variety of manufacturing and system processes.

M-16i, the Solution for:

- Assembly
- Dispensing
- Material handling
- Machine load/unload
- Material removal
- Waterjet cutting

Benefits

- Large work envelope and load capacity allow robot operation in a wide range of high-speed, medium-payload manufacturing processes.
- “Double-jointed” arm increases work envelope and positioning flexibility.
- No robot modification required for upright, inverted, angle and wall mounting.
- Absolute serial encoders eliminate the need for calibration at power-up.
- Unique hollow RV speed reducers simplify cable routing.
- Small footprint facilitates placement in tight surroundings.
- Low arm mass and rigid design allow high-speed, precise positioning.

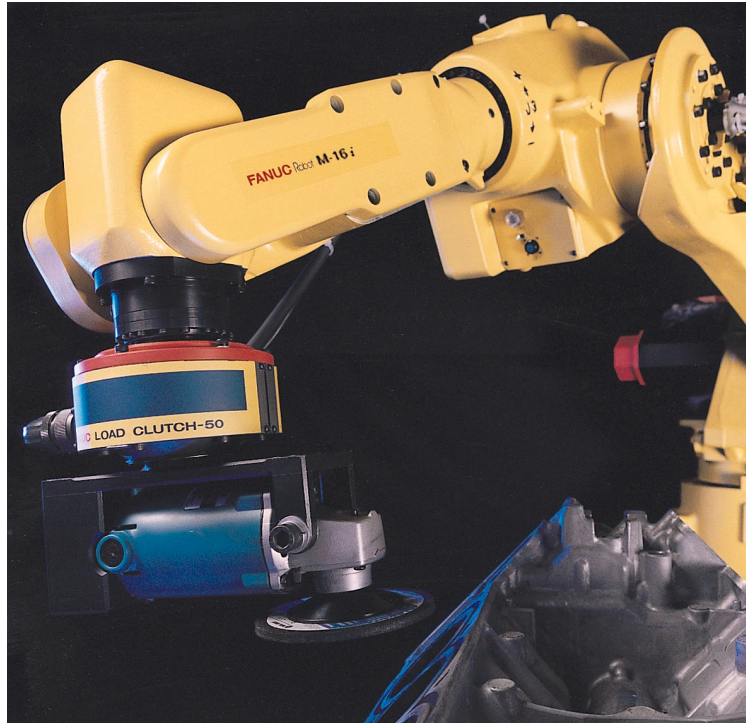

- Electrical and pneumatic services for tooling are internal to the arm to simplify integration.
- Fail-safe brakes on all axes increase safety, functionality and control.

Features

- 6 axes of motion
- 16kg payload capacity
- 0.08mm repeatability
- Axes speeds up to 450° per second

Reliability Features

- Sealed bearings and drives, and brushless AC motors minimize maintenance.
- Grease fittings on all lubrication points for quick and easy maintenance.

- Uses directly-coupled drives, which are more reliable than belts, pulleys or chains.
- All motors, cables and tooling services are engineered to prevent snagging and damage from chips, sprays and other hazards.
- Dust and water resistant design maximizes durability.
- Quick disconnect robot connecting cables.
- In-line wrist design minimizes complexity and eliminates bevel gear adjustments.

Options

- Axis 2 motor cover
- Severe dust and liquid protection package for die cast spray, waterjet cutting and other harsh environment applications (standard M-16i wrist is rated IP67 to withstand temporary immersion in liquids).

FANUC
Robotics

M-16i/iL Dimensions

Isometric

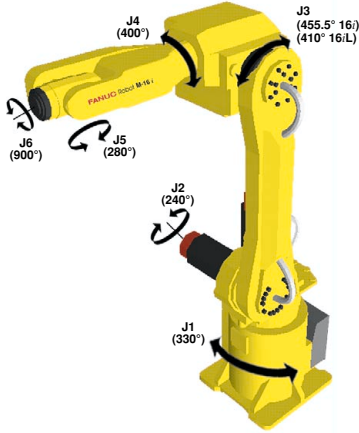

Wrist

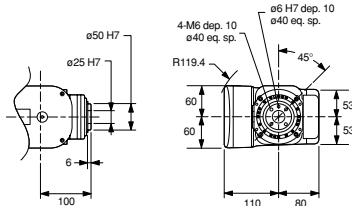

M-16i/iL Specifications

Items	M-16i	M-16iL
Axes	6	6
Payload (kg)	16	10
Reach (mm)	1605	1813
Repeatability (mm)	±0.08	±0.10
Interference radius (mm)	312	312
Motion range (degrees)	J1	330
	J2	240
	J3	455.5
	J4	400
	J5	280
	J6	900
Motion speed (degrees/sec.)	J1	140
	J2	140
	J3	140
	J4	330
	J5	330
	J6	450
Wrist moment (kgf m)	J4	3.6
	J5	3.2
	J6	1.6
Wrist inertia (kgfcm²)	J4	8.7
	J5	7.1
	J6	2.0
Mechanical brakes	All axes	All axes
Mechanical weight (kg)	270	270
Mounting method	Floor, ceiling, angle and wall	Floor, ceiling, angle and wall
Installation environment	Temperature °C	0 to 45
	Humidity	Normally: 75% or less Short term (within a month): 95% or less No condensation
Vibration (m/s²)	4.9 or less	4.9 or less
IP Rating(s)	Body IP54 std. (IP55 optional) Wrist & J3 arm IP67	Body IP54 std. (IP55 optional) Wrist & J3 arm IP67
Payload at axis 3 (kg)	20	12

Notes:

(1) Motion range is de-rated for wall and angle mount.

Footprint (remote)

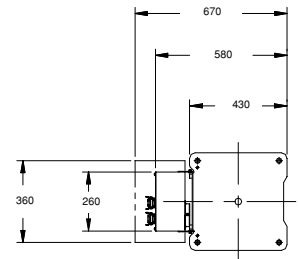

Top

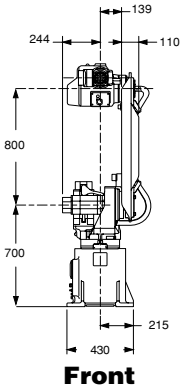
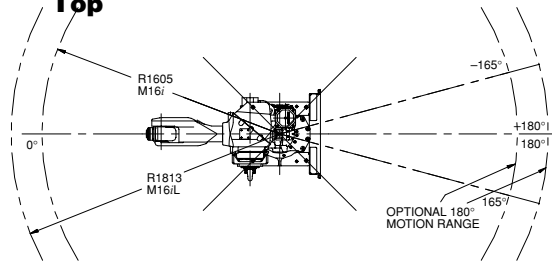

Side (M-16i)

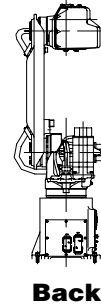
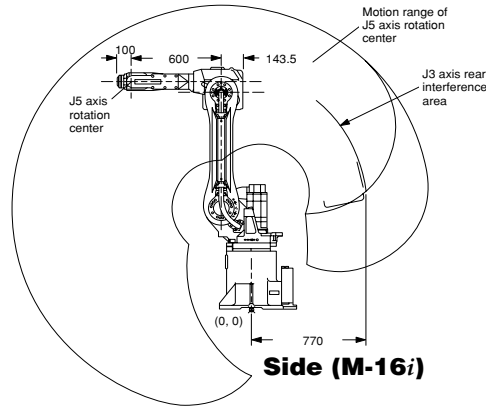

Back

Side (M-16iL)

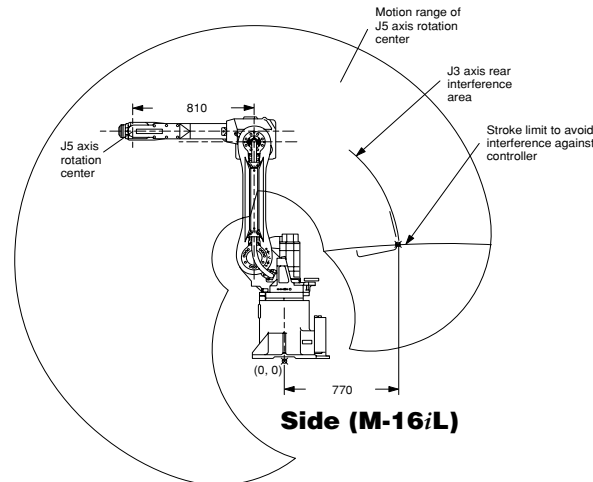

Note: Dimensions shown in millimeters.



FANUC Robotics North America
 3900 W. Hamlin Road
 Rochester Hills, MI 48309-3253
 (248) 377-7000
 Fax (248) 276-4133

Charlotte, NC
 (704) 596-5121
 Chicago, IL
 (847) 898-6000

Toronto, Canada
 (905) 812-2300
 Montréal, Québec
 (450) 492-9001

For sales or technical information, call:
 1-800-47-ROBOT

Cincinnati, OH
 (513) 754-2400

Mexico City, Mexico
 52 (55) 5611-5998

Los Angeles, CA
 (949) 595-2700

Agascalientes, Mexico
 52 (449) 910-8000

marketing@fanucrobotics.com
www.fanucrobotics.com

Toledo, OH
 (419) 866-0788

Sao Paulo, Brazil
 (55) (11) 3955-0599

©2002 FANUC Robotics North America, Inc. All rights reserved. FANUC ROBOTICS LITHO IN U.S.A. FRNA-2/02



For further information contact Motion Controls Robotics at 419.334.5886